

(No Model.)

4 Sheets—Sheet 1.

# E. P. BULLARD. SCREW CUTTING MACHINE.

No. 410,146.

Patented Sept. 3, 1889.

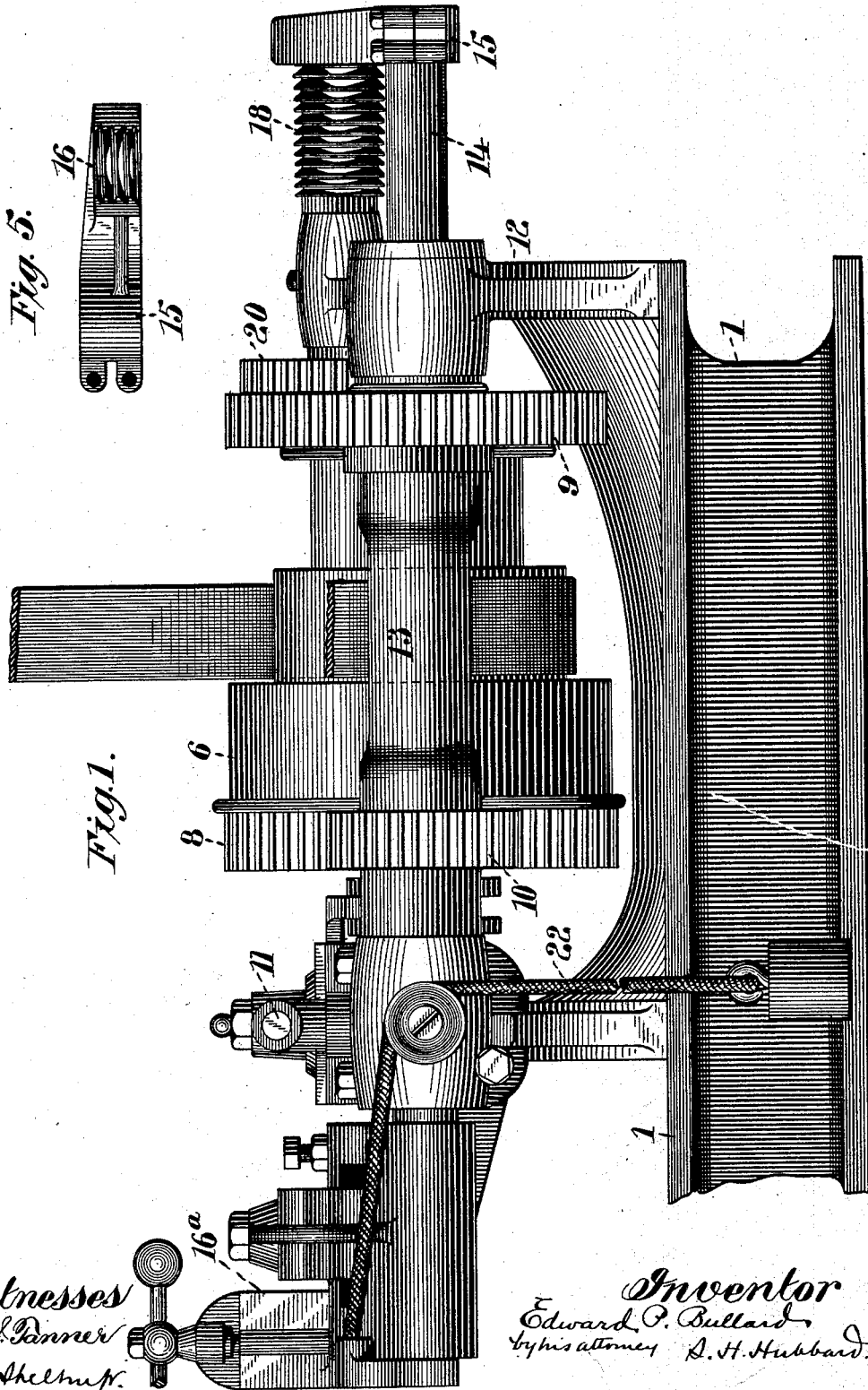

Witnesses  
*H. P. Danner*  
*W. D. Shelton*

Inventor  
*Edward P. Bullard*  
 by his attorney *S. H. Hubbard*

E. P. BULLARD.  
SCREW CUTTING MACHINE.

No. 410,146.

Patented Sept. 3, 1889.

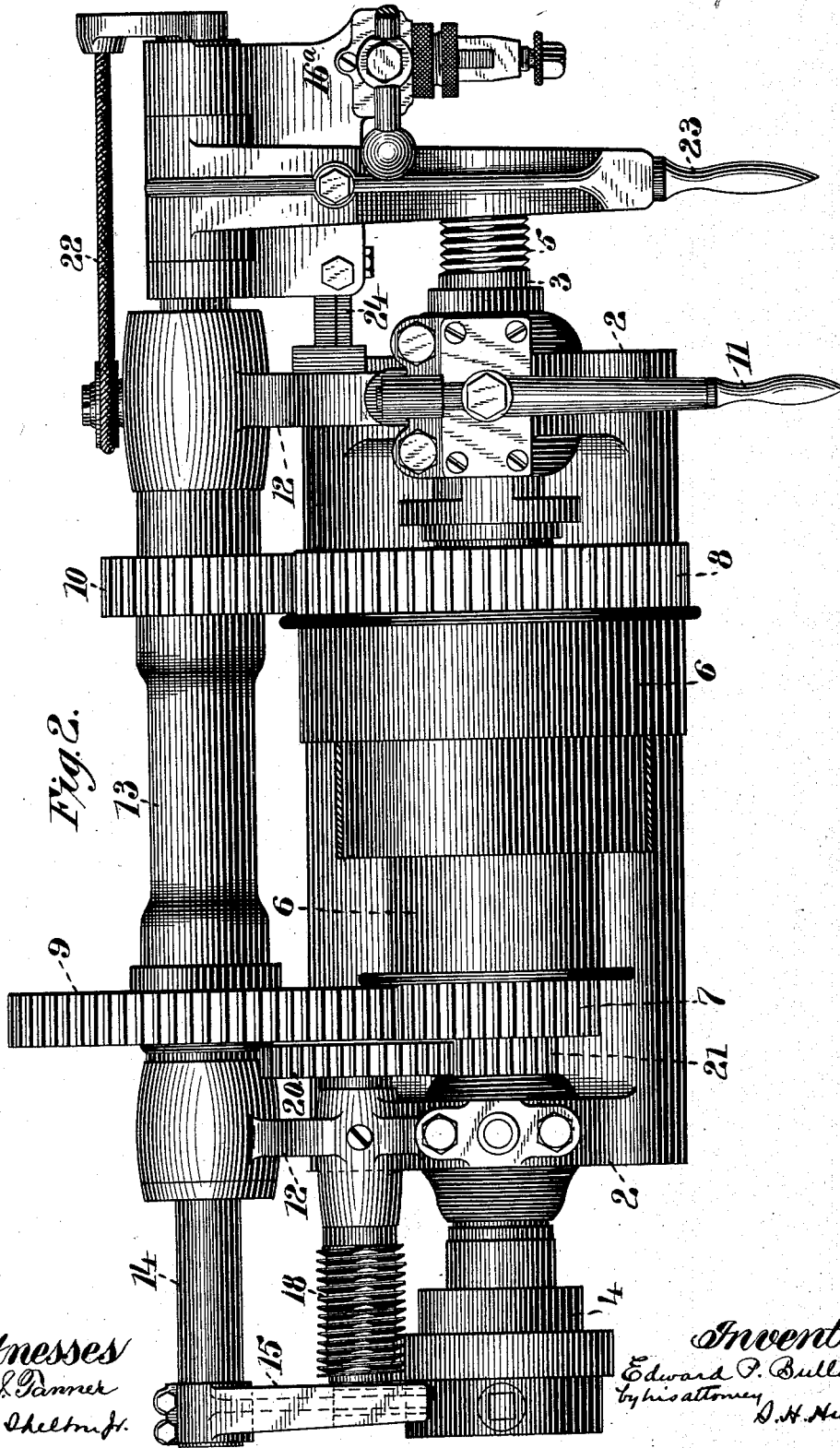

Fig. 2.

Witnesses  
Wm. J. Tanner  
N. J. Shelton.

Inventor  
Edward P. Bullard,  
by his attorney  
D. H. Hubbard

E. P. BULLARD.  
SCREW CUTTING MACHINE.

No. 410,146.

Patented Sept. 3, 1889.

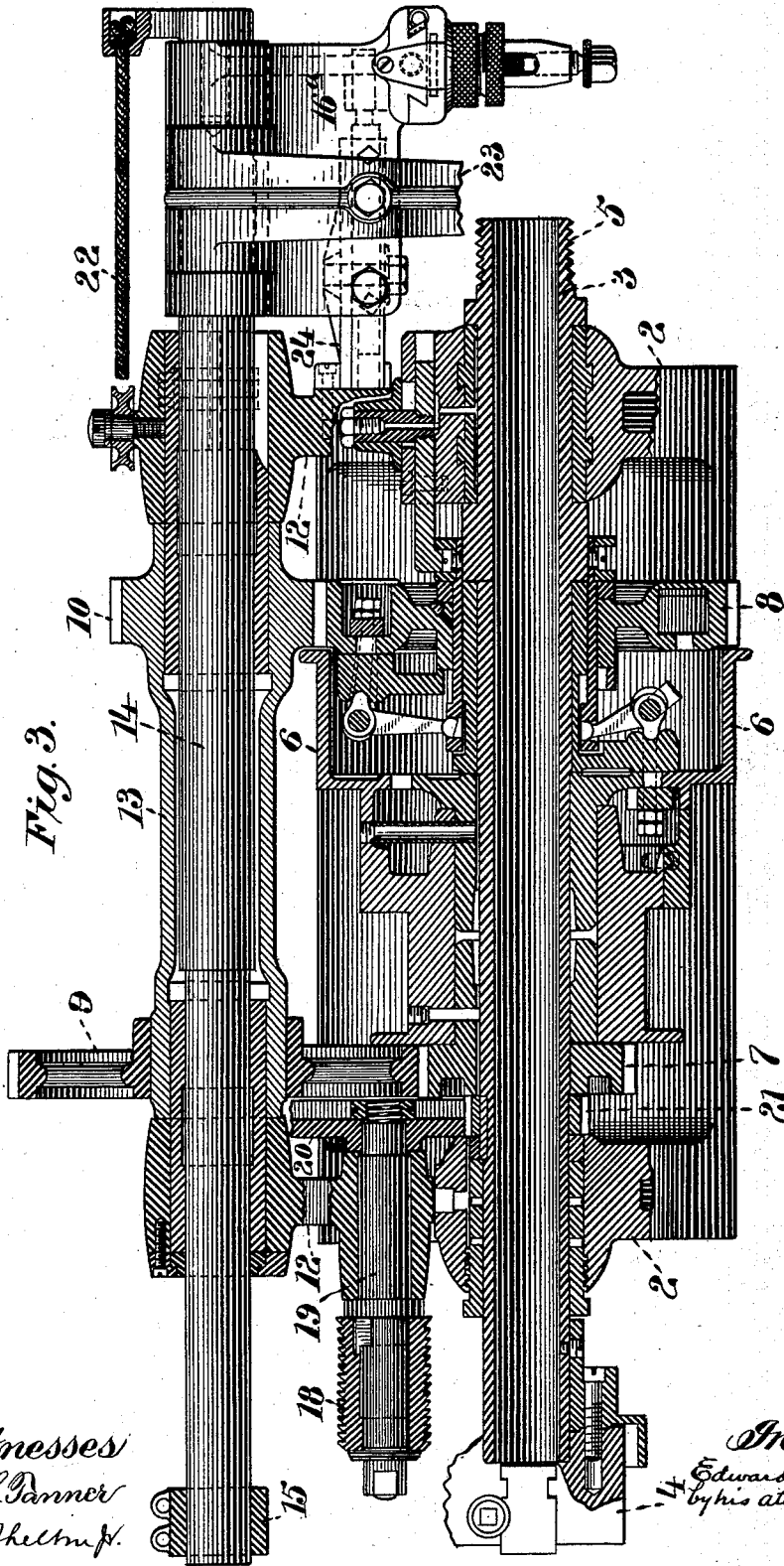

Fig. 3.

Witnesses  
 Wm. P. Danner  
 N. D. Shelton

Inventor  
 Edward P. Bullard  
 by his attorney  
 J. H. Hubbard

(No Model.)

4 Sheets—Sheet 4.

E. P. BULLARD.  
SCREW CUTTING MACHINE.

No. 410,146.

Patented Sept. 3, 1889.

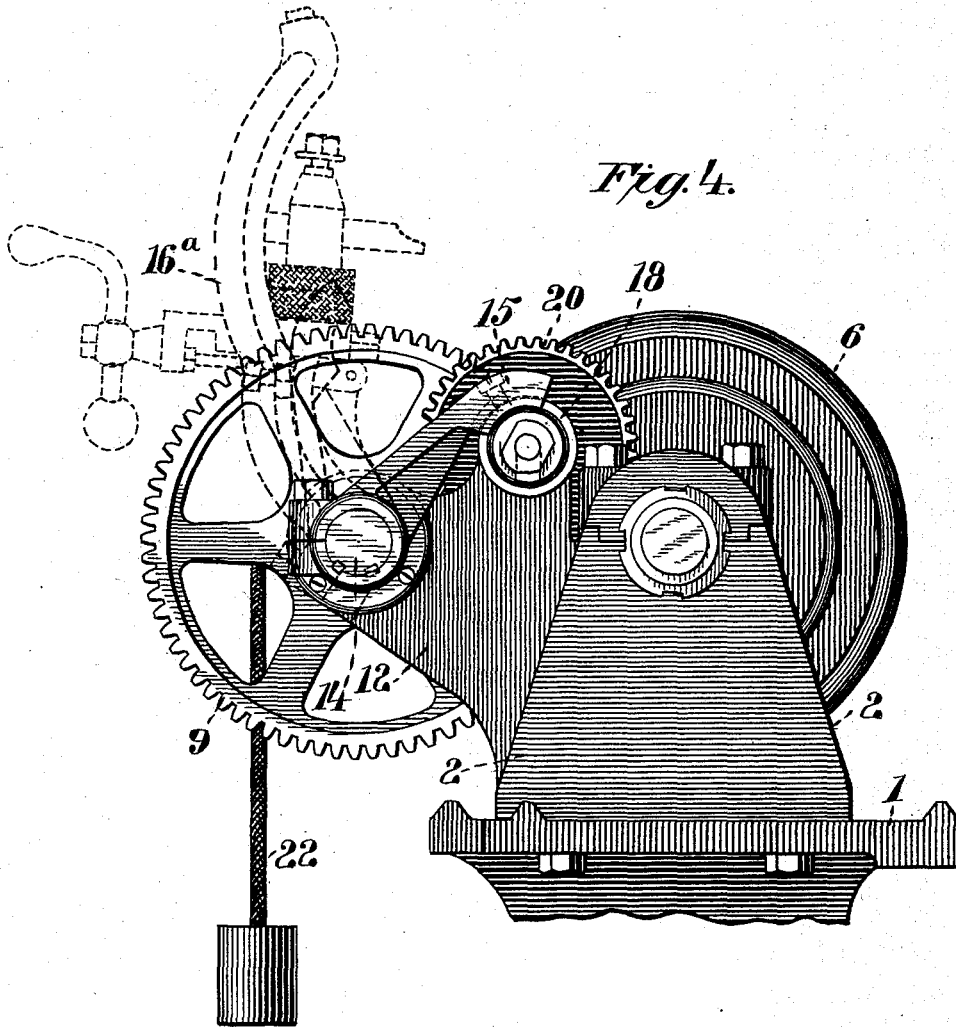

*Witnesses*  
*Wm. J. Tanner*  
*H. J. Shelton Jr.*

*Inventor*  
*Edward P. Bullard*  
*by his attorney J. H. Hubbard*

# UNITED STATES PATENT OFFICE.

EDWARD P. BULLARD, OF BRIDGEPORT, CONNECTICUT.

## SCREW-CUTTING MACHINE.

SPECIFICATION forming part of Letters Patent No. 410,146, dated September 3, 1889.

Application filed June 25, 1889. Serial No. 315,469. (No model.)

*To all whom it may concern:*

Be it known that I, EDWARD P. BULLARD, a citizen of the United States, residing at Bridgeport, in the county of Fairfield and State of Connecticut, have invented certain new and useful Improvements in Screw-Cutting Machines; and I do hereby declare the following to be a full, clear, and exact description of the invention, such as will enable others skilled in the art to which it appertains to make and use the same.

My invention relates to certain new and useful improvements in screw-cutting machines, but more particularly to such machines as are used in cutting large screws for assembling heavy machinery and like uses; and the object of my invention is to provide a simple and compact construction which shall be easy of operation, and in which undue complication shall be avoided, and furthermore and particularly does it consist in the arrangement of the chaser-bar within and extending through the back-gear quill and standards, whereby strength and economy of space are promoted; and with these ends in view my invention consists in the construction and combination of elements hereinafter fully and in detail explained, and then recited in the claims.

In order that those skilled in the art to which my invention appertains may fully understand its construction and method of operation, I will describe the same in detail, reference being had to the accompanying drawings, which form a part of this specification, and in which—

Figure 1 is a rear side elevation; Fig. 2, a plan view; Fig. 3, a horizontal longitudinal section, the tool-carriage appearing in plan view; Fig. 4, a rear end elevation showing the leader arm and nut in full lines in feeding position, and said arm and nut and the tool-carriage in dotted lines in their raised position; Fig. 5, a detail bottom plan of the leader-arm and leader-screw nut.

Like reference-numerals denote the same parts in all the figures of the drawings.

While the machine herein shown and described is a complete and operative screw-cutting machine, the lathe-spindle, back gears, and other parts not essential for screw-cutting are usually combined with a tool-post,

tail-stock, and other elements which go to make an operative lathe when mounted in proper juxtaposition to the spindle. As these parts have no connection with my present invention, I have shown the bed 1 as broken away in front of the chuck. Upon the bed 1, heretofore referred to, are standards 2, in which a hollow spindle 3 is journaled. At its rear end said spindle is provided with any ordinary holding-chuck 4, and at its forward end it is screw-threaded at 5 for securing thereon, if desired, another chuck of any suitable construction, whereby the bar to be threaded may be held firmly as against rotation when presented to the tool. By this means the bar to be operated upon may be held at the rear end or the forward end, or both.

Arranged around the spindle near its central portion is the coned belt-pulley 6, to which power is applied, and also the gears 7 8, which, together with the gears 9 10 at the rear of the machine, comprise the back-gear mechanism, by means whereof the spindle may be given either of two different speeds, at the option of the operator.

The clutch mechanism (not lettered) at the inside of the coned pulley, and which is operated by means of the handle 11, serves either to lock the coned pulley directly to the spindle, in which case the latter is carried directly by the said pulley and the gear 8 caused to run loose from the pulley, or it locks the said pulley fast to the gear 8 and releases it from the spindle, in which case the movement of the spindle is derived from the pulley through the gears 8 10 9 7, in the order named. This clutch is shown, described, and claimed in certain Letters Patent of the United States for improvement in lathe head-stocks granted to William S. Halsey, June 28, 1887, No. 365,681, and of which I am the owner by assignment. I have not therefore deemed it necessary to enter into any detailed description of it, particularly as any similar mechanism might be employed in connection with my present invention. At the rear side of the machine, and in the same horizontal plane with the spindle, are the back-gear standards 12, in which is journaled the quill 13, carrying thereon the gears 9 10. Through this quill is extended the chaser-bar 14, which is movable longi-

itudinally therein, and also axially. At its rear end it has secured upon and projecting outwardly from it the leader-arm 15, upon which is carried the leader-screw feed-nut 16. (See Fig. 5.) At the other end of the chaser-bar is secured the tool-post bracket 16<sup>a</sup>, which has mounted therein a tool-post, the latter having feeding mechanism, as a sliding head 17, for adjusting the tool relative to the work. It has also a handle 23, whereby the bracket may be lifted, the chaser-bar being turned in the quill.

18 is the leader-screw, mounted on a short shaft 19 at the rear end of the machine, between the spindle and quill. This short shaft carries a gear 20, which is engaged and driven by a gear 21, carried by the spindle.

22 is a weight and cord, against whose action the chaser-bar is moved forward, and by means whereof said bar may be moved backward when required.

24 is a way or track extending outward from the end of the machine. The tool-post bracket engages and is adapted to travel thereon when in its cutting position, as seen at Figs. 2 and 3.

In operating the machine the bar upon which the thread is to be cut is passed through the hollow spindle, wherein it is secured either by the chuck 4 or, when the forward end of the spindle is provided with a chuck, as hereinbefore set forth, by both chucks. The handle 23 having been lifted so as to raise the bracket and tool-post and tool upward clear of the bar, and the leader-screw nut likewise upward clear of the screw, the chaser-bar is allowed to be drawn backward in the quill by the weight and cord 22 as far as is desired. The handle is then lowered, so as to bring the tool-post and tool into proper position relative to the bar to be cut and the leader-screw nut into engagement with the leader-screw. Then if the machine be started, so as to revolve the chuck and the bar to be threaded, the leader-screw, which, as heretofore set forth, is rotated from the spindle through the gears 20 21, will, by engaging the leader-screw nut, feed the chaser-bar and tool-carriage bracket and tool carried thereby forward, whereby a spiral whose pitch is determined by the pitch of the

leader-screw is cut by the tool upon the rotating bar held in the chuck.

For cutting different threads, leader-screws varying in pitch may be employed, the leader-screw nut being changed to correspond. The tool-post and means for feeding and adjusting the tool therein may be of any ordinary construction, as may also be the chucks and the clutch mechanism in the pulley, as heretofore set forth.

I claim—

1. In a screw-cutting machine, the combination, with the hollow spindle and means for revolving the same, of the back-gear quill and the back gears, the leader-screw and means for operating it, the chaser-bar extending through the quill and back-gear standards, and the leader-screw nut and tool-holding devices mounted upon and carried by the chaser-bar, substantially as set forth.

2. In a screw-cutting machine, the combination, with the hollow spindle provided with means, as the chucks, for holding the work therein, of the belt-pulley whereby power is applied to the spindle, the back-gear standards and quill arranged parallel with said spindle, the leader-screw and means for rotating it, the chaser-bar extending through the quill, the leader arm and nut secured upon one end of said bar and adapted to engage the leader-screw, and the tool-post bracket and carriage secured upon the other end of the chaser-bar, substantially as set forth.

3. In a screw-cutting machine, the combination, with the hollow spindle, the chuck secured thereto, and the belt-pulley whereby said spindle is rotated, of the back-gear standards and the quill carrying the back gears, and the chaser-bar extended through said quill and back-gear standards, said bar carrying the leader-screw nut and the tool-holding device, substantially as specified.

In testimony whereof I affix my signature in presence of two witnesses.

EDWARD P. BULLARD.

Witnesses:

GEO. N. MOREHOUSE,  
S. H. HUBBARD.